

APPROVED

REVISIONS				
ZONE	REV.	DESCRIPTION	DATE	APPROVED

**INFORMATION IN THIS DRAWING
PROVIDED FOR REFERENCE ONLY**

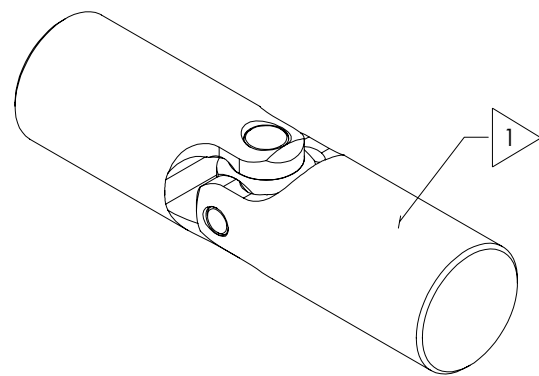

SCALE 1.5 : 1

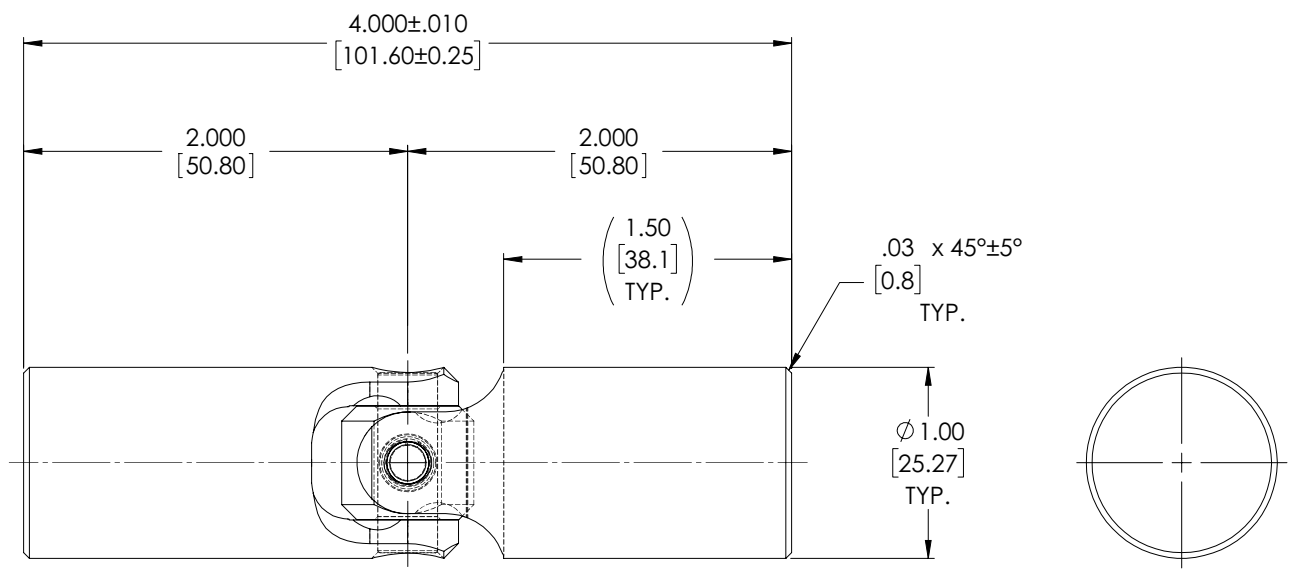

NOTE(s), UNLESS OTHERWISE SPECIFIED.

1 MARK ASSEMBLY w/ "BELDEN" LOGO, PART NUMBER, REVISION LEVEL (IF ANY), DATE OF MANUFACTURE & BELDEN JOB No.

(2) LUBRICATE w/ LUBRIPLATE 1200-2, NLGI GRADE 2, AW/EP LITHIUM GREASE OR EQUIVALENT.

(3) REF., MATERIAL: YOKES... TYPE 316/316L STAINLESS STEEL,
BLOCK & PINS... TYPE 316/316L STAINLESS STEEL,
RETAINING RING... TYPE 316 STAINLESS STEEL, PASSIVATED.

DO NOT SCALE DRAWING

UNLESS OTHERWISE SPECIFIED CHAMFER ALL HOLES BREAK ALL SHARP CORNERS DE-BURR ALL FEATURES TURNED SURFACES: \checkmark 63 MILLED SURFACES: \checkmark 125 PROPRIETARY AND CONFIDENTIAL THE INFORMATION CONTAINED IN THIS DRAWING IS THE SOLE PROPERTY OF BELDEN UNIVERSAL. ANY REPRODUCTION IN PART OR AS A WHOLE WITHOUT THE WRITTEN PERMISSION OF BELDEN UNIVERSAL IS PROHIBITED.	STANDARD TOLERANCES, UNLESS OTHERWISE SPECIFIED DIMENSIONS ARE IN INCHES [mm]	MATERIAL STAINLESS STEEL	INITIALS DATE DRAWN RNK 06MAR08	Belden Universal www.beldenuniversal.com ASSEMBLY, UNIVERSAL JOINT, STAINLESS STEEL	
	ANGULAR MACHINED: ±1.0° FRACTIONAL: ±.015° TWO PLACE DECIMAL: ±.010° THREE PLACE DECIMAL: ±.005° FOUR PLACE DECIMAL: ±.0005° CONCENTRICITY: .00025 T.I.R.	HEAT TREAT NONE	CHECKED RNK 06MAR08 ENG APPR. RNK MFG APPR. QC APPR.		TITLE:
	ALL HOLES TO BE LOCATED ON CENTERLINE (C) WITHIN .005" T.I.R. INTERPRET GEOMETRIC TOLERANCES I.A.W. ASME Y14.5	FINISH NONE	COMMENTS:		SIZE DWG. NO. REV A UJ-SS1000-316 A
	SCALE: 2:1 WT (Lbs): 0.814 SHEET 1 OF 2				SHEET 1 OF 2